

# Bushfire Protection

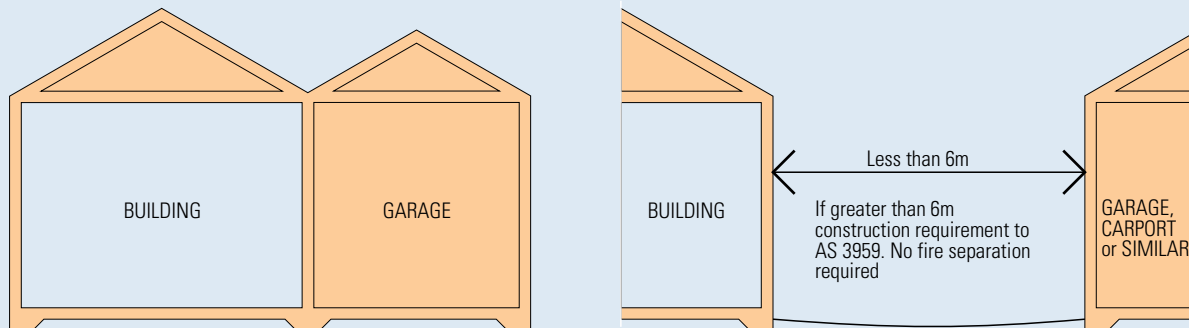

Attached or adjacent within 6m roofed structures such as garages, carports, verandas and the like, and garages or carports below the building must have the same level of protection as the main building, or be separated from it by 60 minute fire rated wall and/or floor:



*(include drawing of garage/carport below the building)*

For detailed fire rating requirements for attached/adjacent structures refer AS 3959-2009.

This brochure outlines Boral lightweight fire rated solutions that satisfy the requirements of AS3959-2009 Construction of buildings in bushfire – prone area. These solutions offer the designers, builders and owners of bushfire-prone buildings the flexibility of design and construction, and provide cost effective alternatives to traditional construction methods.

For details of Boral lightweight fire rated solutions outlined in this brochure please refer to [www.boral.com.au/bushfireprotection](http://www.boral.com.au/bushfireprotection)

BAL-29	BAL-40	BAL-FZ (FLAME ZONE)
Enclosure by external wall or by steel, bronze or aluminium mesh, non-combustible supports where the sub-floor is unenclosed, naturally fire resistant timber stumps or posts on 75mm metal stirrups	If enclosed by external wall refer below 'External Walls' section in table or non-combustible sub-floor supports or tested for bushfire resistance to AS 1530.8.1	Sub-floor supports – enclosure by external wall or non-combustible with an FRL of 30/-/- or be tested for bushfire resistance to AS 1530.8.2
Concrete slab on ground, enclosure by external wall, metal mesh as above or flooring less than 400mm above ground level to be non-combustible, naturally fire resistant timber or protected on the underside with sarking or mineral wool insulation	Concrete slab on ground, enclosure by external wall or protection or underside with a non-combustible material such as fibre cement sheet or be non-combustible or be tested for bushfire resistance to AS 1530.8.1	Concrete slab on ground or enclosure by external wall or an FRL of 30/30/30 or protection of underside with 30 minute incipient spread of fire system or be tested for bushfire resistance to AS 1530.8.2
Non-combustible material (masonry, brick veneer, mud brick, aerated concrete, concrete), timber framed, steel framed walls sarked on the outside and clad with 6mm fibre cement sheeting or steel sheeting or bushfire resistant timber	Non-combustible material (masonry, brick veneer, mud brick, aerated concrete, concrete) or timber framed or steel framed walls sarked on the outside and clad with 9mm fibre cement sheeting or steel sheeting or be tested for bushfire resistance to AS 1530.8.1	Non-combustible material (masonry, brick veneer, mud brick, aerated concrete, concrete) with minimum thickness of 90mm or an FRL of -/30/30 when tested from outside or be tested for bushfire resistance to AS 1530.8.2
Protected by bushfire shutter, or screened with steel, bronze or aluminium mesh, or 5mm toughened glass with openable portion screened and frame of metal or metal reinforced PVC-U, or bushfire resisting timber and portion within 400mm of ground level screened	Protected by bushfire shutter or 5mm toughened glass. Openable portion screened with steel or bronze mesh	Protected by bushfire shutter or FRL of -/30/- and openable portion screened with steel or bronze mesh or be tested for bushfire resistance to AS 1530.8.2
Protected by bushfire shutter, or screened with steel, bronze or aluminium mesh or non-combustible, or 35mm solid timber for 400mm above threshold. Metal or bushfire resisting timber framed tight-fitting with weather strips at base	Protected by bushfire shutter, non-combustible or 35mm solid timber, metal framed tight-fitting with weather strips at base	Protected by bushfire shutter or tight-fitting with weather strips at base and an FRL of -/30/-
Non-combustible covering. Roof/wall junction sealed. Openings fitted with non-combustible ember guards. Roof to be fully sarked	Non-combustible covering. Roofing/wall junction sealed. Openings fitted with non-combustible ember guards. Roof to be fully sarked and no roof mounted evaporative coolers	Roof with RFL of 30/30/30 or tested for bushfire resistance to AS 1530.8.2. Roof/wall junction sealed. Openings fitted with non-combustible ember guards. No roof mounted evaporative coolers
Enclosed sub-floor space or non-combustible or bushfire resistant timber supports. Decking to be non-combustible	Enclosed sub-floor space or non-combustible supports. Decking to be non-combustible	Enclosed sub-floor space or non-combustible supports. Decking to have no gaps and be non-combustible

# Introduction

In addition to other provisions of the Building Code of Australia, residential buildings in defined bushfire-prone areas, and attached non-habitable buildings such as garages, sheds and the like, must comply with the requirements of the Australian Standard AS 3959-2009 Construction of buildings in bushfire – prone areas.

While bushfire protection requirements for the lower five BAL categories range from ember protection to the use of non-combustible materials, BAL-FZ requires 30min fire rating of the building envelope elements and sub-floor structure. Buildings in a particular BAL category may adopt higher BAL requirements if additional level of safety is desired.

Bushfire protection requirements for various Bushfire Attack Levels are outlined in the table below:

Bushfire Attack Level (BAL)	Description of predicted bushfire attack and level of exposure
BAL - LOW	There is insufficient risk to warrant specific construction requirements
BAL - 12.5	Ember attack
BAL - 19	Increasing levels of ember attack and burning debris ignited by windborne embers together with increasing heat flux between 12.5 and 19 kW m <sup>2</sup>
BAL - 29	Increasing levels of ember attack and burning debris ignited by windborne embers together with increasing heat flux between 19 and 29 kW m <sup>2</sup>
BAL - 40	Increasing levels of ember attack and burning debris ignited by windborne embers together with increasing heat flux with the increased likelihood of exposure to flames
BAL - FZ	Direct exposure to flames from fire front in addition to heat flux and ember attack

	BAL - LOW	BAL - 12.5	BAL - 19
<b>SUBFLOOR SUPPORTS</b>	No special construction requirements	No special construction requirements	No special construction requirements
<b>FLOORS</b>	No special construction requirements	No special construction requirements	No special construction requirements
<b>EXTERNAL WALLS</b>	No special construction requirements	As for BAL - 19	External walls – Parts less than 400mm above ground, or decks, etc, to be of non-combustible material, 6mm fibre cement clad or bushfire resistant/naturally fire resistant timber
<b>EXTERNAL WINDOWS</b>	No special construction requirements	As for BAL - 19 except that 4mm Grade A safety glass can be used in place of 5mm toughened glass	Protected by bushfire shutter, completely screened with steel, bronze or aluminium mesh or 5mm toughened glass or glass blocks within 400mm of ground, deck, etc. Openable portion metal screened with frame of metal or metal reinforced PVC-U or bushfire resisting timber
<b>EXTERNAL DOORS</b>	No special construction requirements	As for BAL - 19 except that door framing can be naturally fire resistant (high density) timber.	Protected by bushfire shutter, or screened with steel, bronze or aluminium mesh or glazed with 5mm toughened glass, non-combustible or 35mm solid timber for 400mm above threshold, metal or bushfire resisting timber framed for 400mm above ground, decking, etc, tight-fitting with weather strips at base
<b>ROOFS</b>	No special construction requirements	As for BAL - 19	Non-combustible covering. Roof/wall junction sealed. Openings fitted with non-combustible ember guards. Roof to be fully sarked
<b>VERANDA DECKS, ETC</b>	No special construction requirements	As for BAL - 19	Enclosed sub-floor space – no special requirement for materials except within 400mm of ground. No special requirements for supports or framing. Decking to be non-combustible or bushfire resistant within 300mm horizontally and 400mm vertically from a glazed element

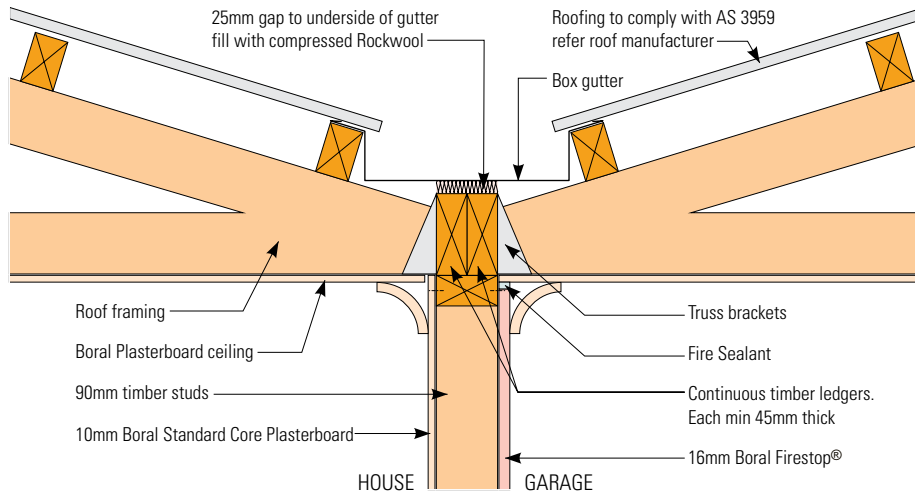

**FRL 60/60/60 Uncommon Roof Space - Attached Structure**

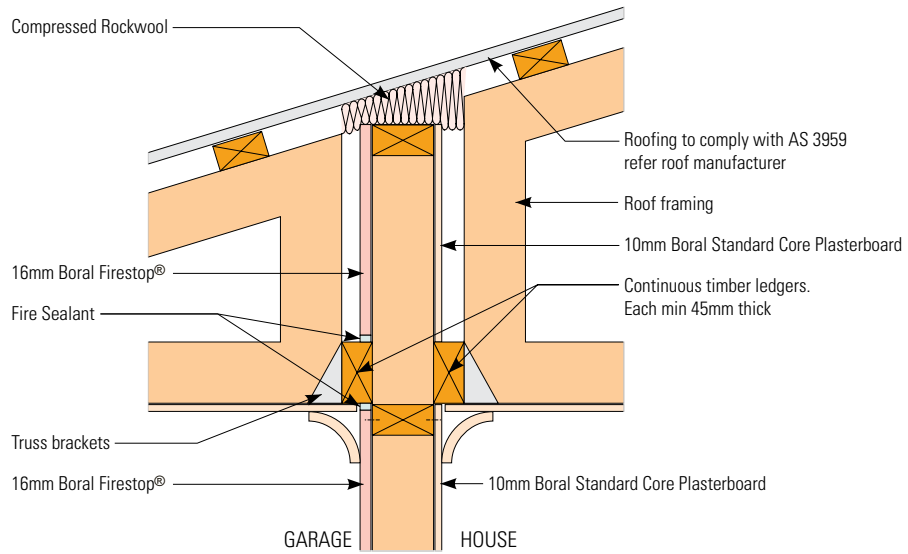

**FRL 60/60/60 Common Roof Space - Attached Structure**

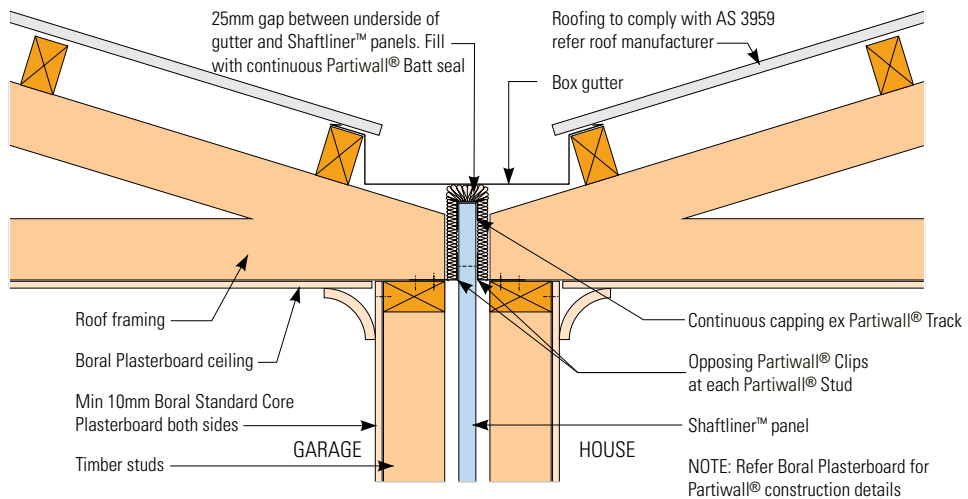

**FRL 60/60/60 Uncommon Roof Space - Attached Structure**



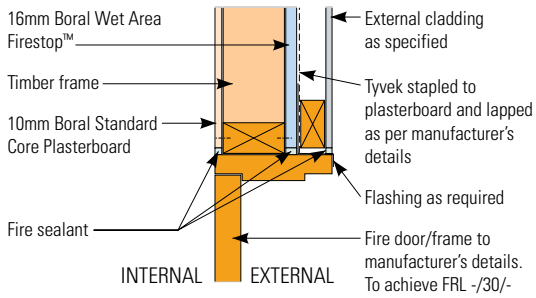

**External Wall and Fire Rated Door Detail**

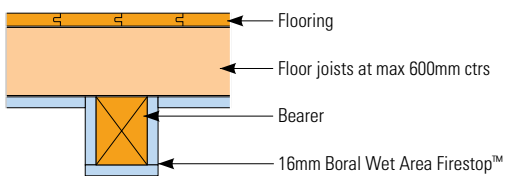

**FRL 30/30/30 Floor/Ceiling Protection for Unenclosed Sub-floor**

ILLUSTRATIVE

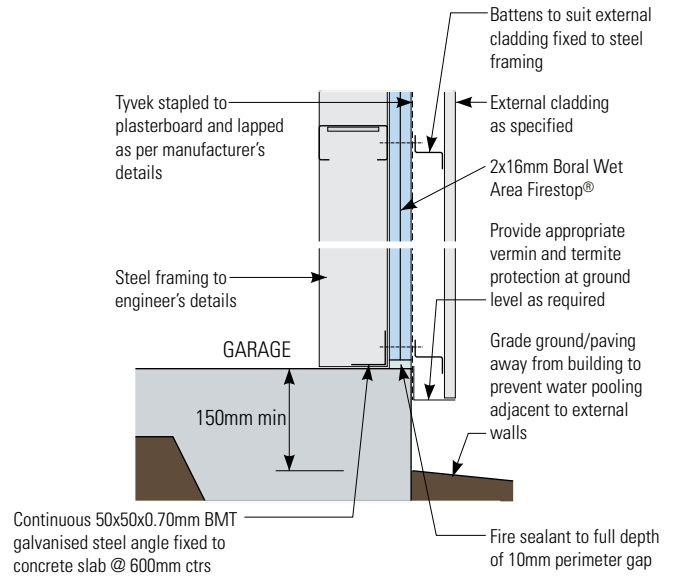

**FRL 60/60/60 External Wall Steel Frame - Concrete Base**

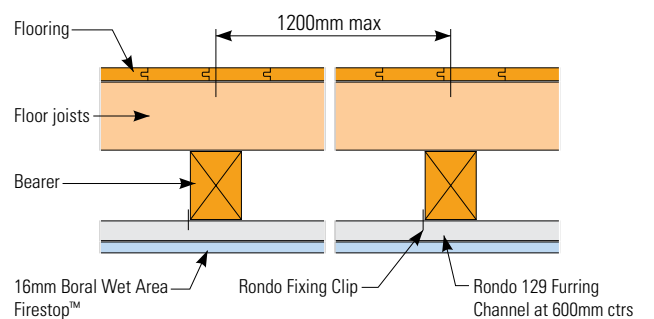

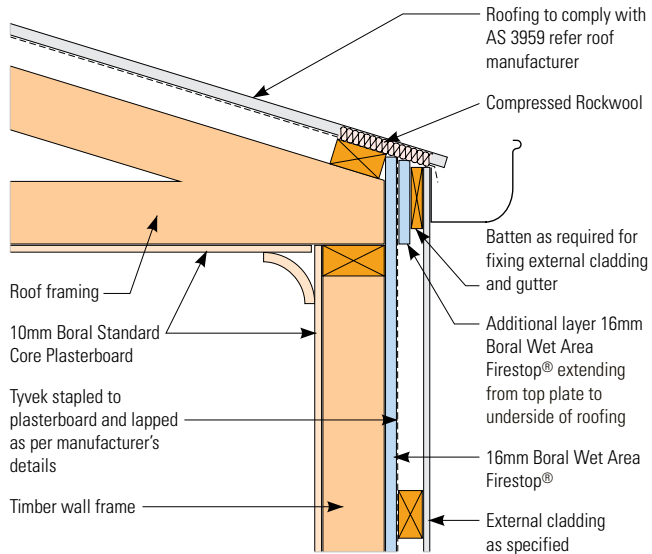

**FRL 60/60/60 External Wall Timber Frame - Roof**

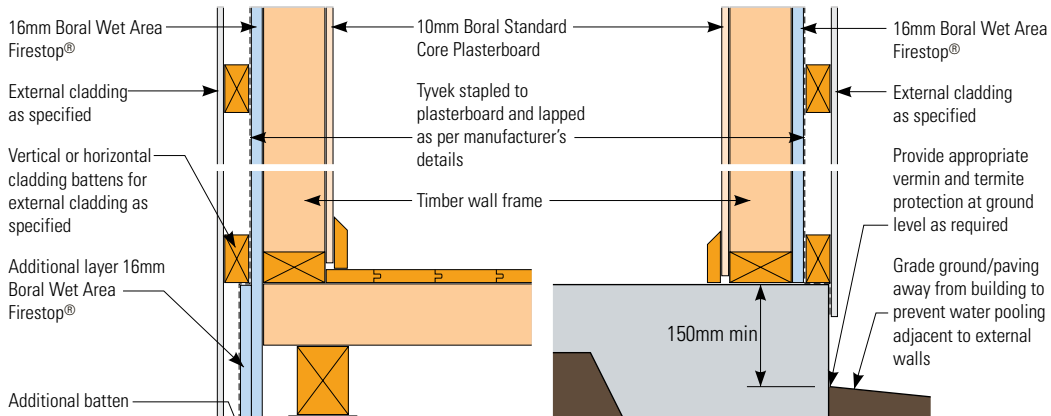

**FRL 60/60/60 External Wall Timber Frame - Concrete Base**

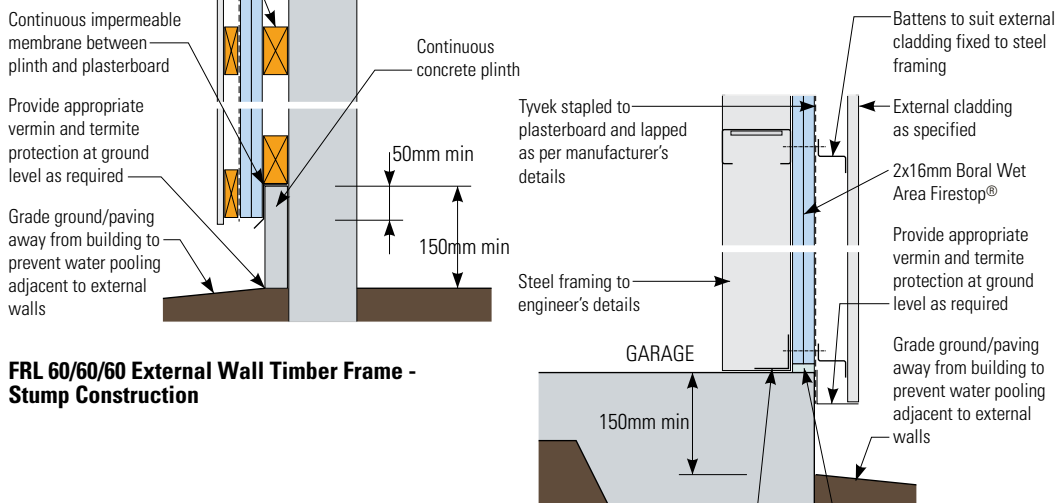

**FRL 60/60/60 External Wall Timber Frame - Stump Construction**

**FRL 60/60/60 External Wall Steel Frame - Concrete Base**

NOTE:  
Refer to Boral Plasterboard Technical Manual for construction details.

Continuous 50x50x0.70mm BMT galvanised steel angle fixed to concrete slab @ 600mm ctrs  
Fire sealant to full depth of 10mm perimeter gap

## Technical Enquiries

**TecASSIST®**  
add a valuable member to your team  
**1800 811 222**

TecASSIST® provides technical advice to builders, architects, contractors, distributors, engineers, regulators and home owners throughout Australia. Our friendly team can offer both practical and design input at all levels of the plasterboard industry.

*Get your next project off on the right track by giving TecASSIST® a call weekdays 8.30am - 4.30pm AEST.*

## Sustainability

Boral Plasterboard aims to minimise the environmental impact of its operations and to make a positive difference to the environment and communities in which it operates. Its products are manufactured from sustainable gypsum resources and 100% recycled paper liner.

Lightweight plasterboard construction offers the benefits of low embodied energy, enhanced indoor air quality, ease of

thermal and acoustic upgrading and ease of modifications and repair.

Plasterboard waste can be recycled back into new plasterboard or used as a soil conditioner. Please contact Boral Plasterboard regarding waste collection services available in your region.

TecASSIST® Fax: (03) 9645 1812

Email: [tecassist@boral.com.au](mailto:tecassist@boral.com.au)

## Sales Offices

### ACT

7 Barrier St, Fyshwick 2609  
Telephone (02) 6280 4243  
Facsimile (02) 6280 5816

### New South Wales

3 Thackeray St, Camellia 2142  
Telephone (02) 9638 0571  
Facsimile (02) 9638 5557

### Northern Territory

Cnr Coonawarra Rd & Mataram St  
(PO Box 38245) Winnellie 0820  
Telephone (08) 8984 4484  
Facsimile (08) 8984 3778

### Queensland

22 Kirra St, Pinkenba 4008  
Telephone (07) 3115 7300  
Facsimile (07) 3115 7321

### South Australia

39 Burleigh Ave, Woodville North 5012  
Telephone (08) 8240 8888  
Facsimile (08) 8341 1004

### Tasmania

93 Albert Rd, Moonah 7009  
Telephone (03) 6278 9966  
Facsimile (03) 6278 9865

### Victoria

676 Lorimer St, Port Melbourne 3207  
Telephone (03) 9214 2138  
Facsimile (03) 9646 1912

### Western Australia

41 Rudderham Drive  
North Fremantle 6159  
Telephone (08) 6226 9825  
Facsimile (08) 6226 9833

### Export Department

676 Lorimer St, Port Melbourne 3207  
Telephone (03) 9214 2121  
Facsimile (03) 9645 2873  
Email [tecexport@boral.com.au](mailto:tecexport@boral.com.au)

[www.boral.com.au/bushfireprotection](http://www.boral.com.au/bushfireprotection)

## Guarantee

Products manufactured and supplied by Boral Australian Gypsum Limited (BAGL) A.C.N. 004 231 976 (trading as Boral Plasterboard) are guaranteed to be of consistent quality and free from any defects.

Boral Plasterboard may limit its liability under this guarantee to, at its option, the replacement or payment of the cost of replacing OR supplying equivalent or payment of the cost of supplying equivalent OR the repair or payment of the cost of repairing products found to be defective.

© Copyright Boral Limited 2009

*The technical information contained in this manual was correct at the time of printing. Building systems and details are, however, subject to change. To ensure the information you are using is current, Boral recommends you review the latest building information available on the Boral website. For further information contact TecASSIST® or your nearest Boral Plasterboard Sales Office.*

## Health and Safety

For information regarding the safe use of Boral Plasterboard products and accessories please refer to instructions on the product packaging or contact your local Boral Plasterboard Sales Office or TecASSIST® for a current copy of the Material Safety Data Sheet.

